

# M630

## Barrière Anti Inondation (de 75 cm à 1m20)

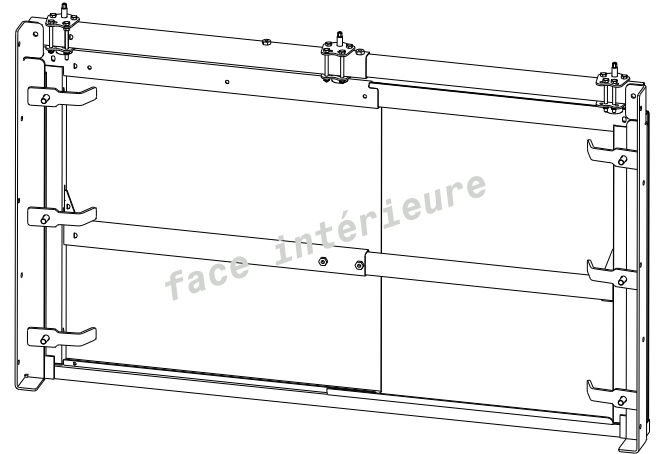
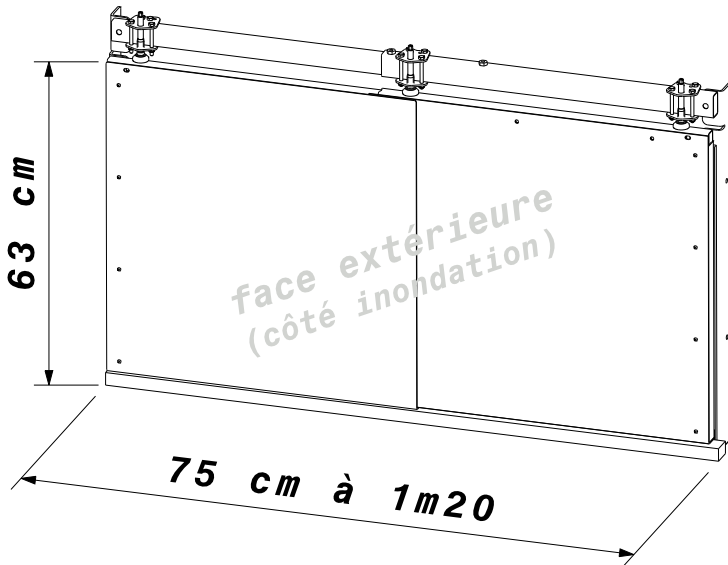

*Vous venez d'acquérir un produit MOTTEZ, conçu et fabriqué en France. Nous vous remercions pour ce choix qui, nous l'espérons, vous apportera entière satisfaction. Voici quelques recommandations indispensables afin de monter et d'utiliser votre barrière anti inondation dans les meilleures conditions*

*La barrière anti-inondation s'installe devant les ouvertures d'un bâtiment afin de protéger l'intérieur d'une crue importante, ou une forte montée des eaux. Ce dispositif évite que les eaux ne s'infiltrent grâce notamment à la compression des différents joints. Les surfaces recevant l'appui des joints ( soit les murs et le sol ) doivent présenter une bonne planéité et très peu d'irrégularités*

*Une mauvaise installation peut avoir des conséquences sur l'étanchéité du produit. Respecter les règles de montage et d'assemblage. Une partie du produit, reste à demeure sur vos murs, les 2 cornières en Aluminium. Les autres parties il faut les maintenir en bon état, afin de pouvoir les utiliser le cas échéant. Conserver les instructions pour s'y référer dans le futur lors de l'installation.*

*Seule votre responsabilité serait engagée en cas de mauvaise utilisation ou de non respect des consignes.*

### SAV Notice de montage, et de réparabilité

Indice de Réparabilité: **10 / 10**

*Si malgré toutes les précautions prises lors de la conception du produit, vous deviez rencontrer un problème, notre Service Après Vente reste à votre disposition. Du lundi au jeudi : de 8h00 à 17h00 et le vendredi de 8h00 à 15h00*



33 (0)3 20 10 90 25



33 (0)3 20 10 37 89



be-sav@mottez.com

Composants /

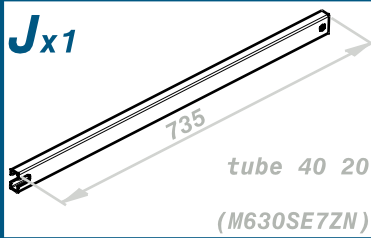
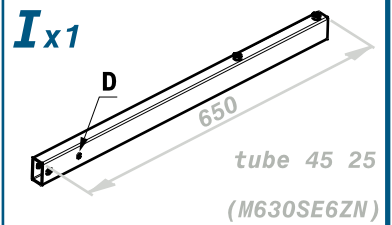
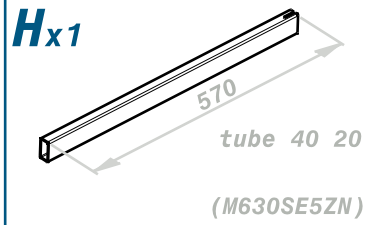
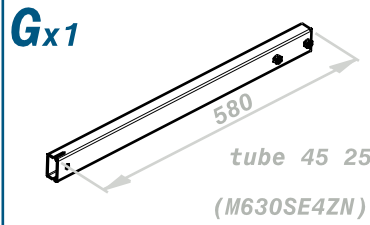
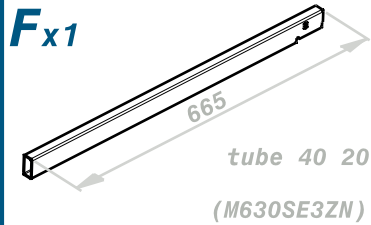
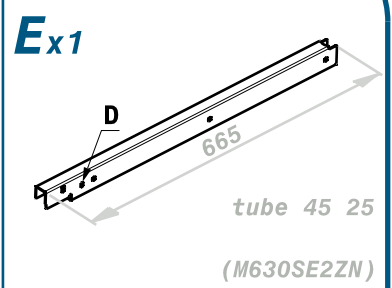
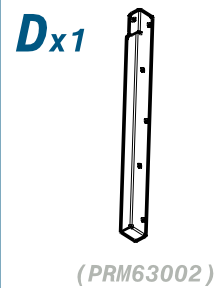
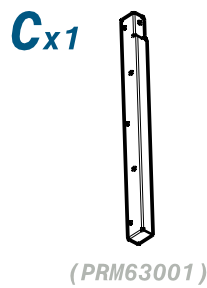
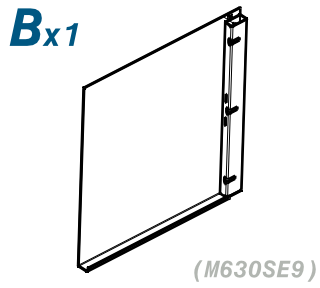
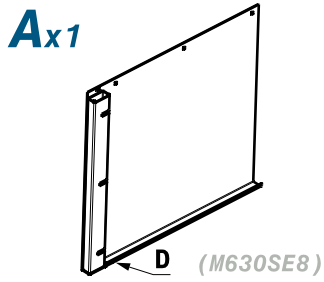

Sachet Accessoires

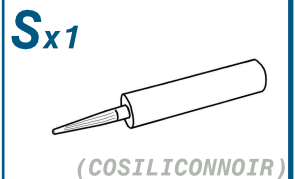
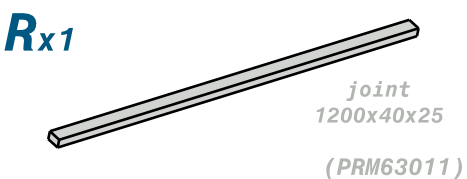
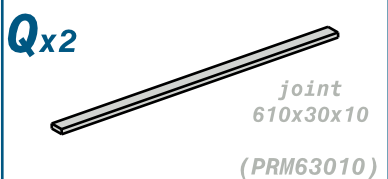
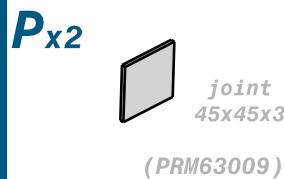
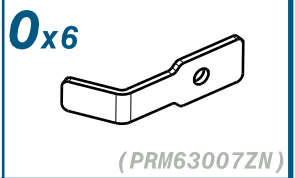
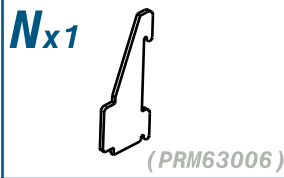
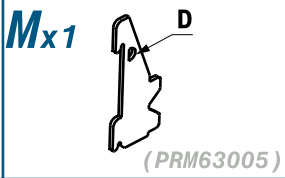
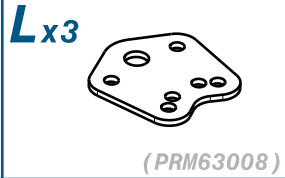
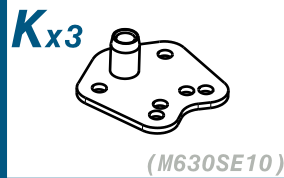

Sachet Visseries

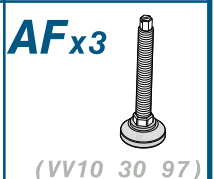
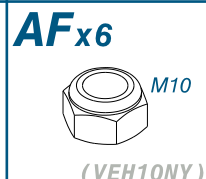
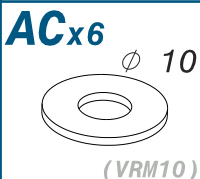
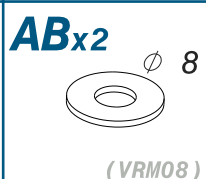
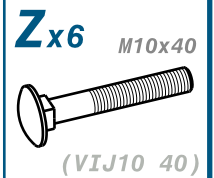
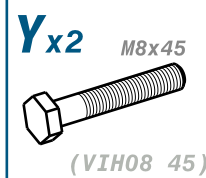
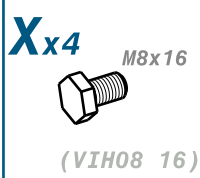
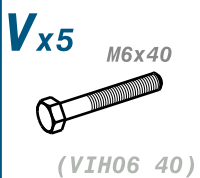
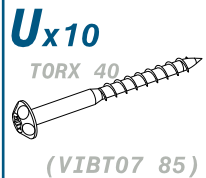
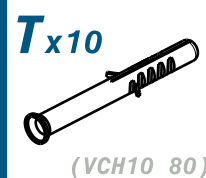

embout TORX 40  
( fourni )



1er montage: 2h



Outils nécessaires au montage (non fournis):

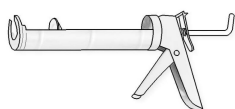
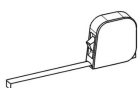

(x2)



(x2)



(x1)

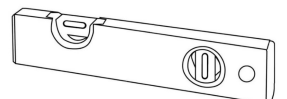

**1**

Mise en place des cornières **C** et **D** qui resteront toujours fixées dans l'embrasure

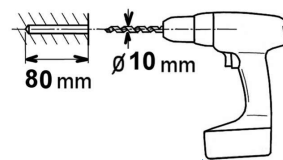
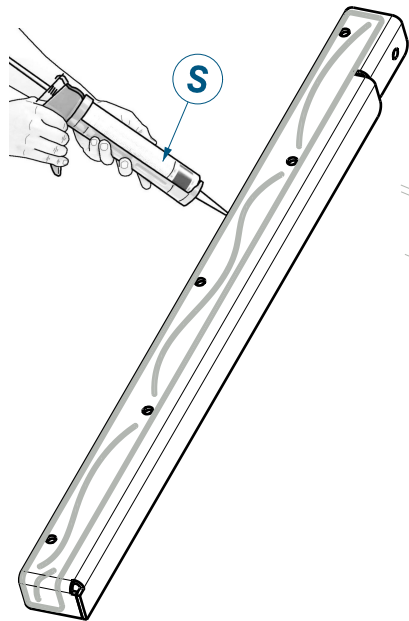
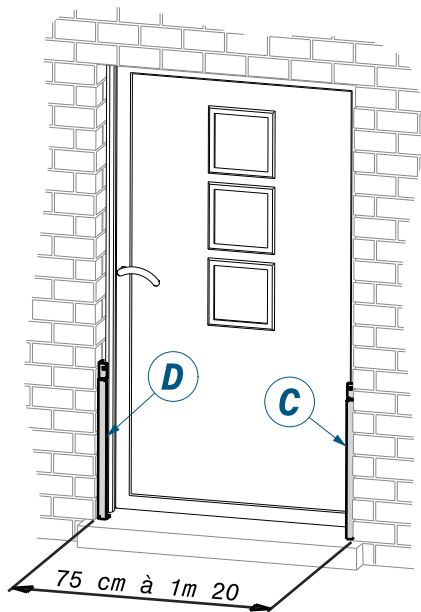

chevilles fournies, prévus pour matériaux plein  
pour matériaux creux, prévoir fixations adéquates

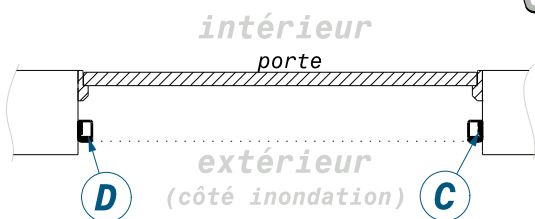
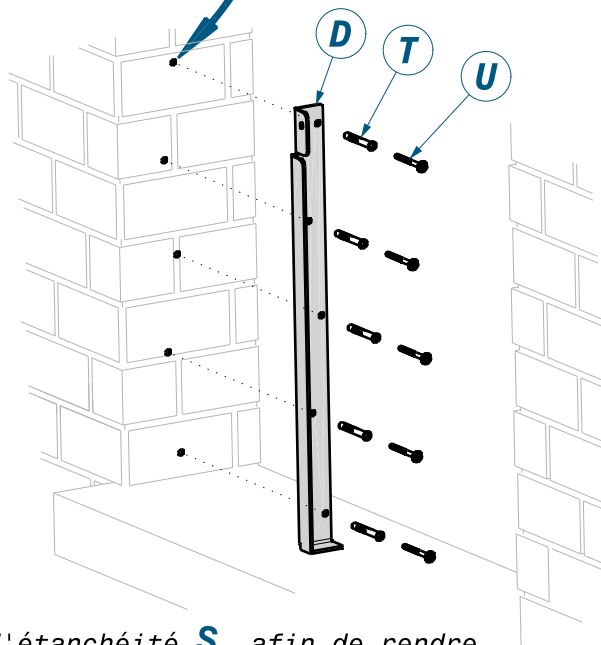

Mettre le mastic d'étanchéité **S**, afin de rendre l'ensemble étanche avec les murs et le sol.

**2**

L'assemblage du panneau principal (avec **A** et **B**) ne se fait qu'une fois. Il suffira de venir le positionner sur les équerres (**C** et **D**) avant une inondation éventuelle.

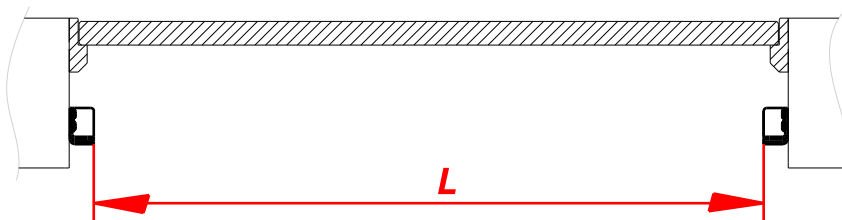
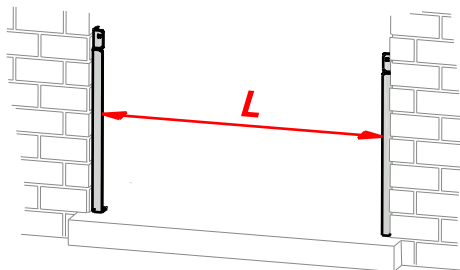

Relever la dimension **L** et la reporter sur la barrière en collant les 2 parties avec le mastic fourni.

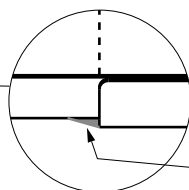
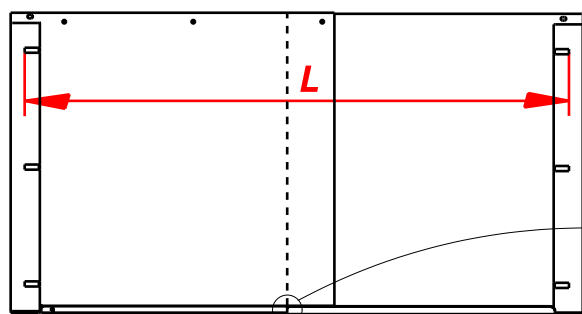
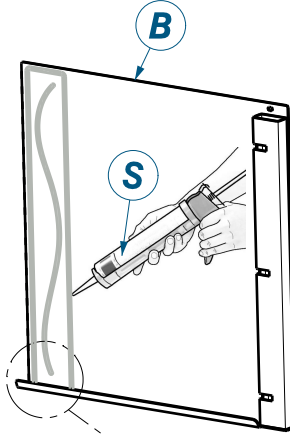
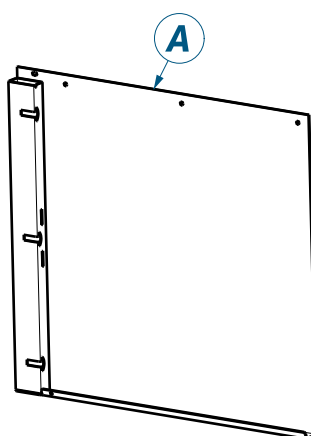
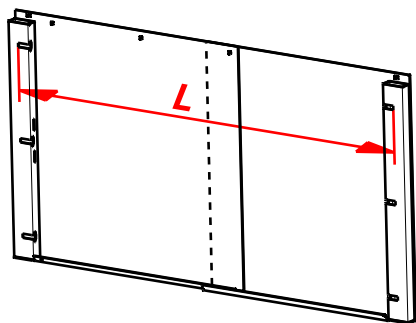

Bien mettre du mastic dans le pli



mettre du mastic "en pente" afin d'éviter une arête tranchante

3

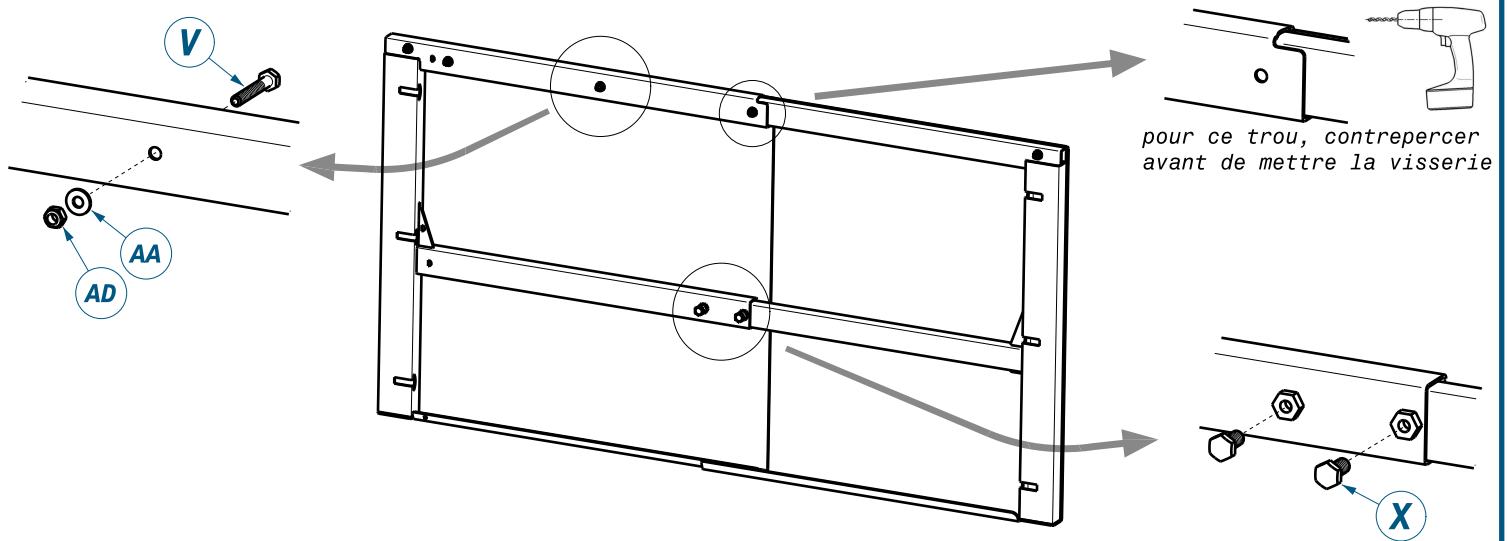
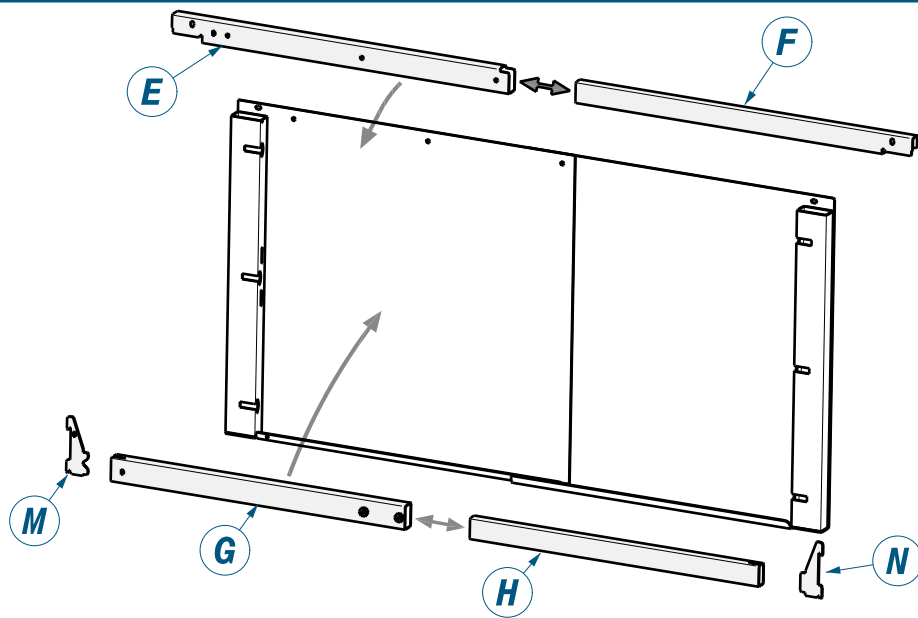

4

Coller les joints d'étanchéité, dans l'ordre suivant **R**, **P** puis **Q**

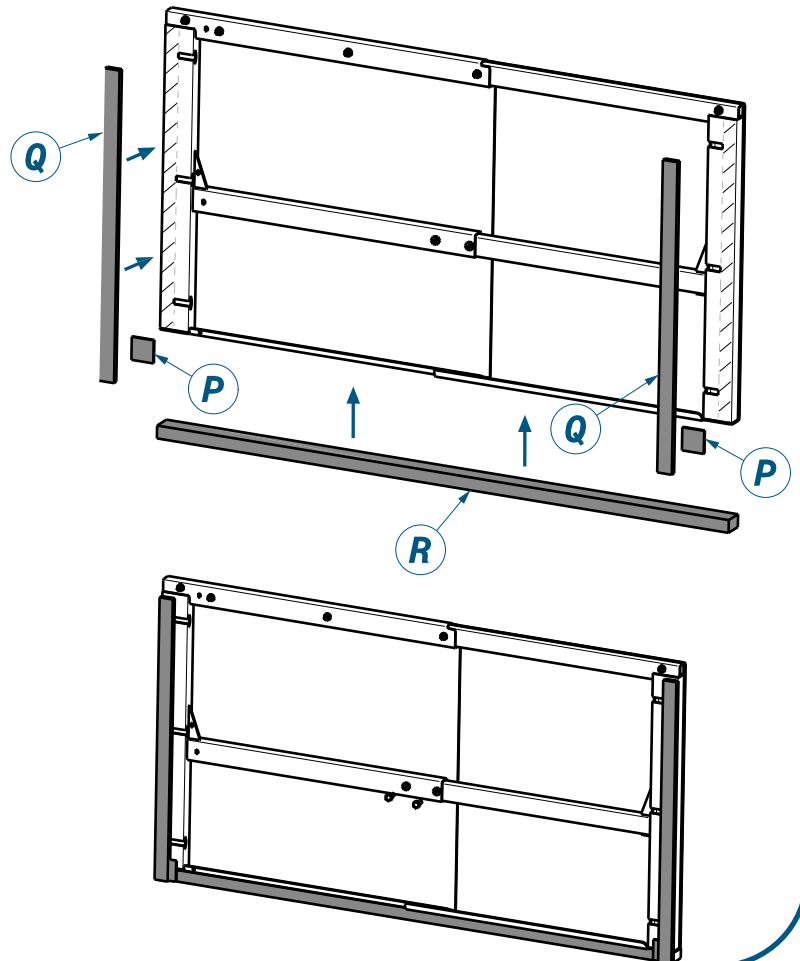
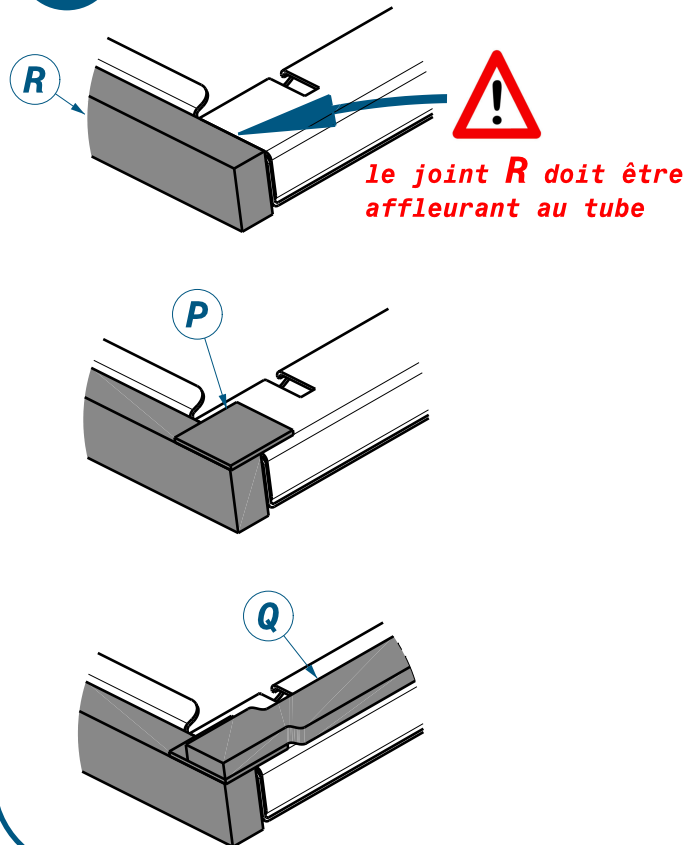

5

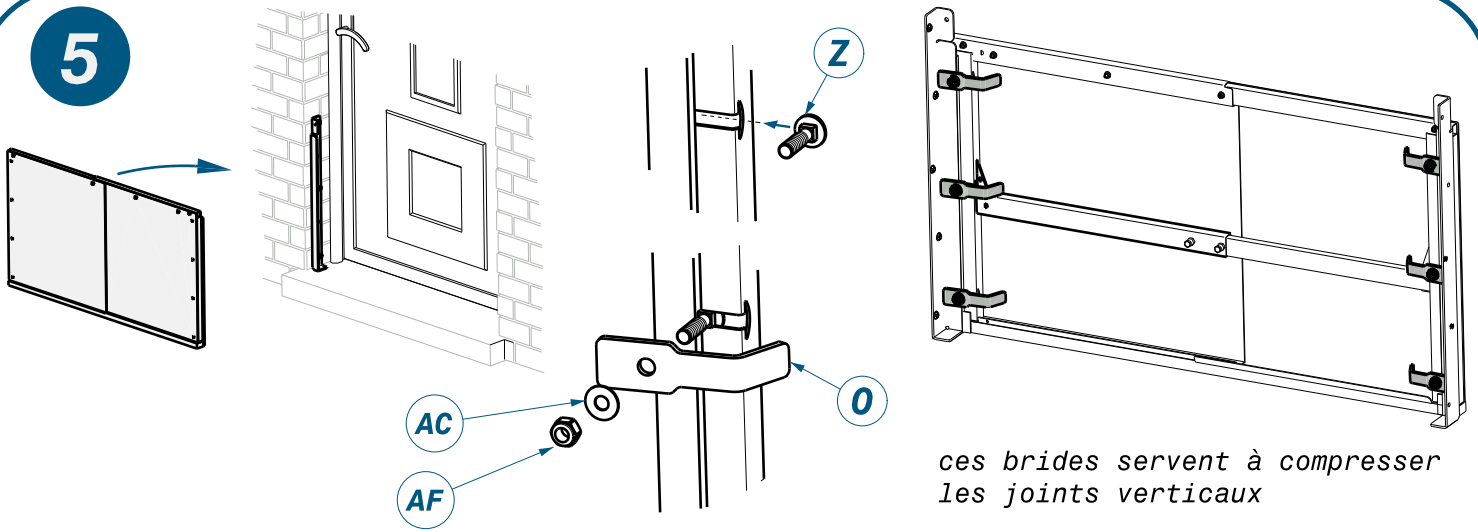

ces brides servent à compresser les joints verticaux

6

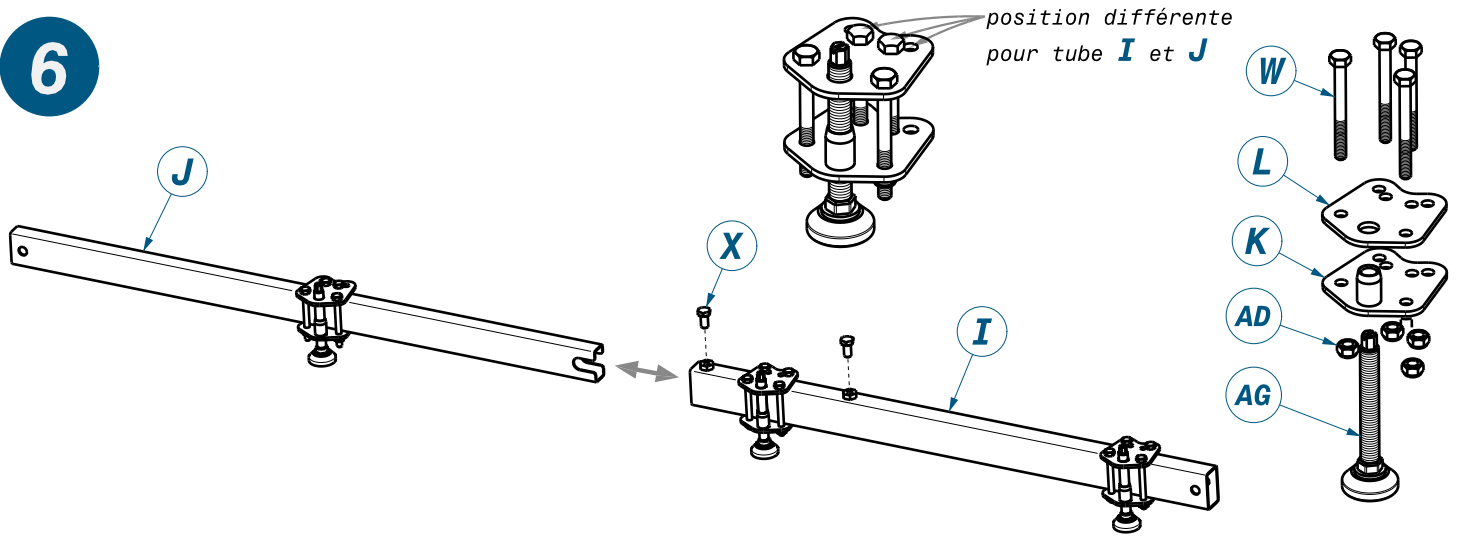

position différente pour tube I et J

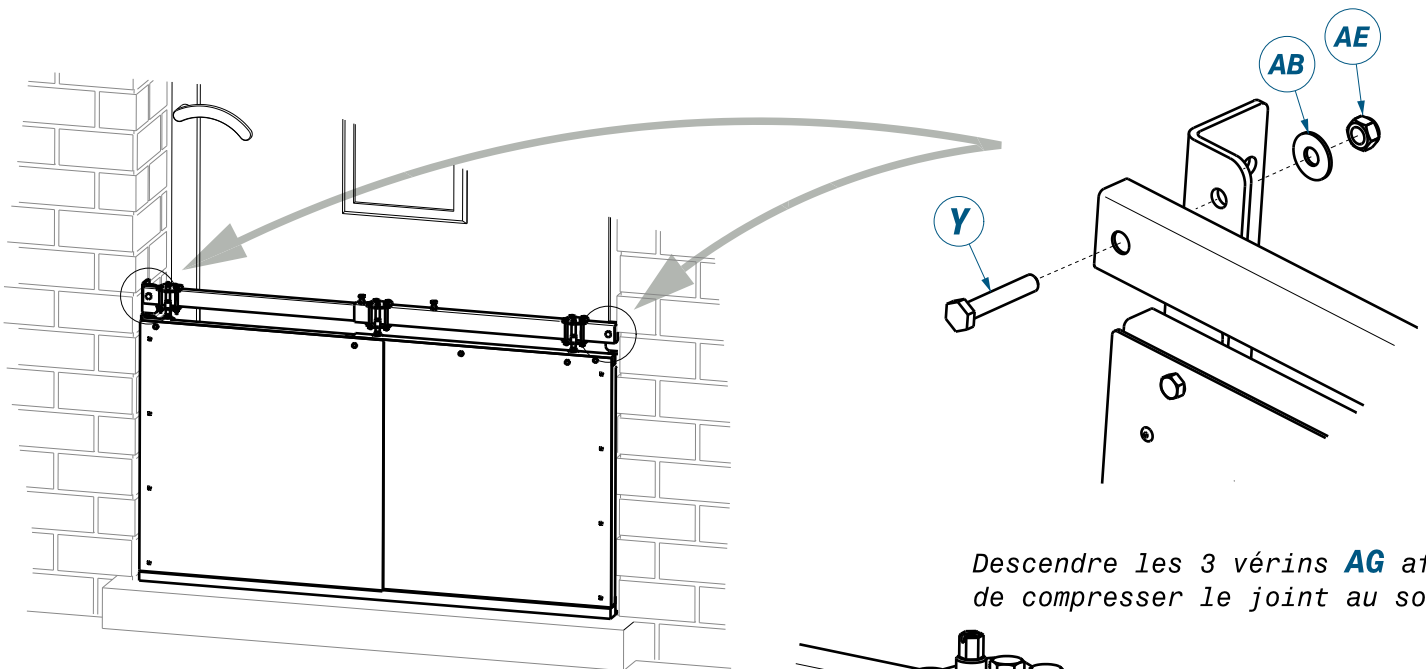

Descendre les 3 vérins AG afin de compresser le joint au sol

